

TT Series

Rotary Indexer





MOTION INDEX DRIVES

ROTARY INDEX DRIVES - TT Series

Programmable Index Drives

The rotary index table transforms a constant input drive motion into a constant output drive motion. The drive motion occurs by means of a hardened and high-accuracy constant lead barrel cam. The use of mathematical laws of motion along with a properly programmed motor profile guarantee a soft, shock proof, and jerk free movement that has been optimally designed for its intended purpose. The design allows for accurate and secure mounting to the output dial. The preload of the cam to the cam followers in dwell ensures the top dial is backlash free. No additional adjustment of the output dial is necessary. The power to rotate the index drive is provided either by means of a three phase AC motor with encoder, coupled to a gear reducer, or a servo motor coupled to a gear reducer. The gear reducer is connected to the input shaft which is firmly connected to the internal barrel cam with no further internal gearing. The barrel cam in turn rotates the top dial through the cam followers with a zero backlash internal design. The output dial is mounted to a wire bearing assembly (4 point contact bearing), which is preloaded to eliminate any runout. The index drive is completely sealed to eliminate intrusion from foreign particulate.

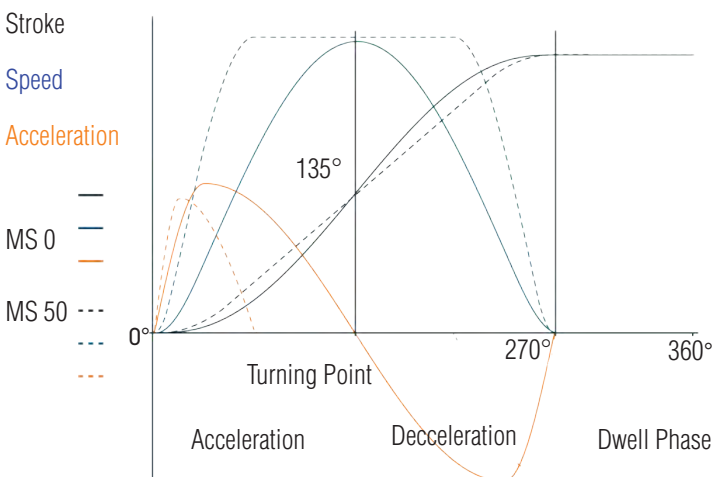
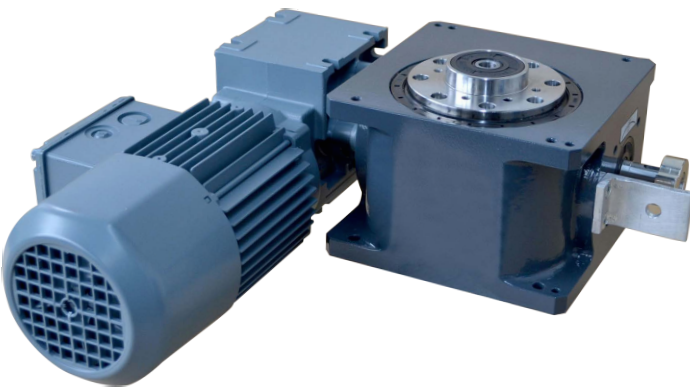

Fixed Index Drives

The rotary index table transforms a constant input drive motion into an intermittent output drive motion. The intermittent drive motion occurs by means of a hardened and high accuracy barrel cam. The use of mathematical laws of motion guarantees a soft, shock-proof, and jerk free movement that has been optimally designed for its intended purpose. The design allows for accurate and secure mounting to the output dial. The preload of the cam to the cam followers in dwell ensures the top dial is backlash free. No additional adjustment of the output dial is necessary.

The power is provided either by means of a three-phase motor via a gear reducer or by means of a timing chain/belt on the drive shaft of the rotary index table. This is firmly connected to the barrel cam without any further internal gear sets, and it turns the cam followers and subsequently the output flange. The output dial is mounted to a wire bearing assembly (4 point contact bearing), which is preloaded to eliminate any runout. The index drive is completely sealed to eliminate intrusion from foreign particulate.

Advantages for design engineers and special machine builder

- Housing machined on all sides. Suitable for use in any mounting position required.
- Mounting holes identical on top and bottom.
- Large center thru-hole which is large enough to feed entire shafts through, and not just small wiring looms.
- Dowel holes in housing and in output flange.
- Recessed center column. No obstruction. Lengthened and machined to customer requirements.
- Simultaneously rotating input shaft extension. Optional synchronization of other mechanical modules.

Options for individual customer requirements

- Choice of drive unit/gear motor.
- Reinforced output flange bearing for higher tilting moment.
- Optional friction clutch on drive
- Dwell and index angle can be tailored to requirements.
- All sizes also available as programmable index tables.
- Custom specified color at no extra charge.

Technical benefits for users

- High reliability and long service life.
- Robust method of construction.
- Hardened cams: smaller sizes for higher load factors.
- Bearings fully immersed in oil bath.
- Cam followers self lubricating through oil bath.
- No wear. Completely maintenance-free.

TT250

Dimensions

The dimensions shown here are the standard dimensions. The output flange, central column, housing and input shafts can be machined to your specifications. The central column can also be designed as a flange. Should you wish to drill additional holes, please consult us with regard to acceptable drilling depth.

*All TT Series tables available in fixed or programmable formats.

A = Length of input shaft

B = Length of shaft to collar

C = Diameter of input shaft

D = Height of central column to supporting surface on output flange, standard is -0.5mm

E = Flange plate as an option

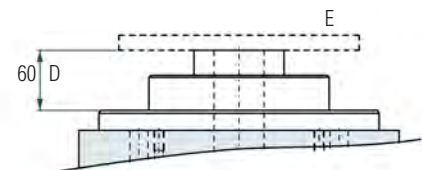
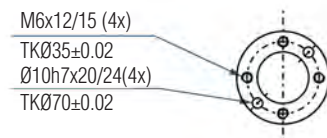
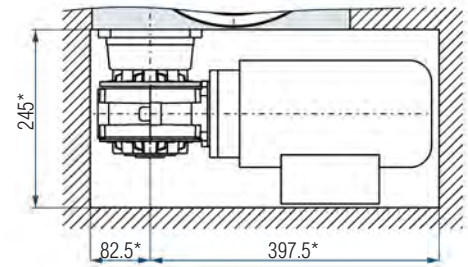
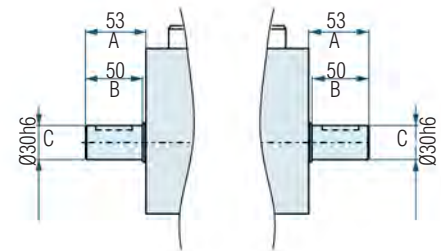
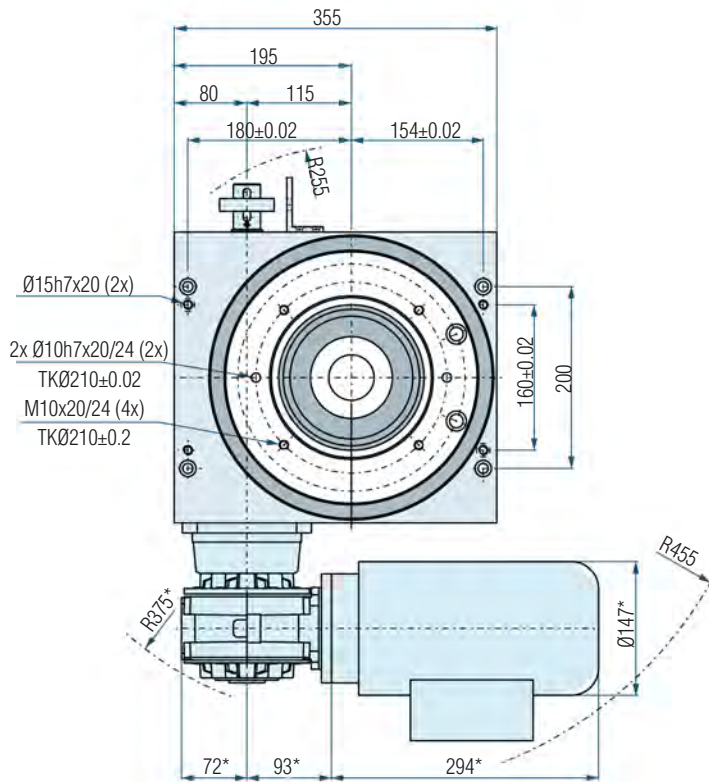
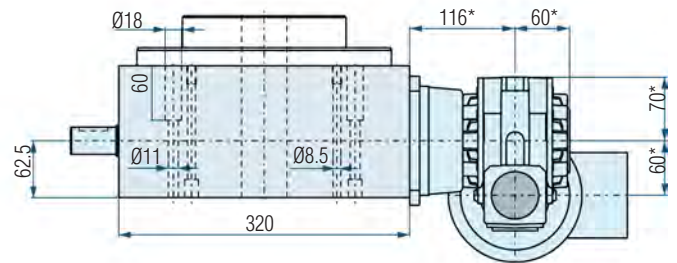
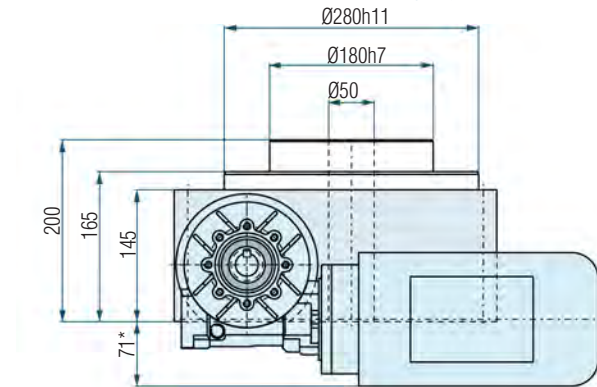

The dimensions for the gearmotor may change based on the gearmotor size and options required for the application.

TT250

Load Table

Scenarios

		1	2	3	4	5	6	7	8	9	10	11	12	
# of Stops	2	t			0.57	0.76	1.07	1.52	1.87	2.13	2.37	2.9	3.33	4.27
		J			3.9	4.78	9.38	19.14	28.86	37.51	46.31	69.55	91.58	150.05
	3	t			0.54	0.71	1	1.43	1.75	2	2.22	2.72	3.13	
		J			6.8	10.39	20.37	41.58	62.7	81.49	100.61	151.09	198.95	
	4	t		0.32	0.48	0.64	0.9	1.29	1.58	1.8	2	2.45	2.81	
		J		3.42	7.71	11.78	23.09	47.12	71.06	92.35	114.01	171.22	225.45	
	5	t		0.32	0.48	0.64	0.9	1.29	1.58	1.8	2	2.45	2.81	
		J		4.33	9.75	17.32	33.94	69.27	104.47	135.77	167.62	251.73	331.47	
	6	t		0.32	0.48	0.64	0.9	1.29	1.58	1.8	2	2.45		
		J		5.9	13.29	23.61	46.28	94.44	142.44	185.11	228.53	343.21		
	8	t		0.32	0.48	0.64	0.9	1.29	1.58	1.8				
		J		9.34	21.02	37.34	73.19	149.37	225.27	292.76				
	10	t		0.32	0.48	0.64	0.9	1.29	1.58	1.8				
		J		12.95	29.16	51.81	101.55	207.24	312.56	406.2				
12	t		0.32	0.48	0.64	0.9	1.29	1.58	1.8					
	J		16.63	37.44	66.51	130.35	266.03	401.21	521.41					
16	t	0.24	0.32	0.45	0.64	0.79	0.9	1	1.23					
	J	10.51	18.67	36.59	74.68	112.63	146.38	180.71	271.4					
20	t	0.24	0.32	0.45	0.64	0.79	0.9	1	1.23					
	J	14.58	25.91	50.77	103.62	156.28	203.1	250.74	376.57					
24	t	0.24	0.32	0.45	0.64	0.79	0.9	1	1.23					
	J	18.72	33.25	65.18	133.01	200.61	260.71	321.86	483.38					
30	t	0.24	0.32	0.45	0.64	0.79	0.9	1						
	J	24.91	44.26	86.75	177.04	267.01	347	428.4						
36	t	0.16	0.21	0.3	0.43	0.53	0.6	0.67	0.82	0.94				
	J	12.48	22.17	43.45	88.68	133.74	173.8	214.57	322.25	424.33				

Technical Specifications

Main Dimensions

Output Flange Ø [mm]	280
Overall Height [mm]	165
Center Opening Ø [mm]	50
Max. size of rotating plate Ø [mm]	2000
# of indexes (other numbers on request)	2,3,4,6,8,10,12,16,20,24,30,36
Index Table weight [kg]	77
Direction	CW, CCW, oscillating
Mounting Position	ANY

Load on output flange

Axial force [kN]	23
Radial force [kN]	24
Tilting moment [kNm]	2

Load on Central column

Axial force [kN]	12
Tilting moment [kNm]	2

Precision

Index precision ["]	±25
Axial Runout [mm] Radial	±0.01
Runout [mm]	±0.01

Standard Drive

Motor	SEW
Gear unit	SEW
Motor size	71-90
Voltage [V]	ANY
Power [kW]	0.18-1.5

* The precision is 5 - 8 angular seconds greater at 16 or more indexes due to multiple dwell positions on the drive cam.



TT315

Dimensions

The dimensions shown here are the standard dimensions. The output flange, central column, housing and input shafts can be machined to your specifications. The central column can also be designed as a flange. Should you wish to drill additional holes, please consult us with regard to acceptable drilling depth.

All TT Series tables available in fixed or programmable formats.

A = Length of input shaft

B = Length of shaft to collar

C = Diameter of input shaft

D = Height of central column to supporting surface on output flange, standard is -0.5mm

E = Flange plate as an option

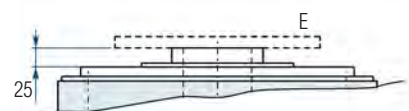
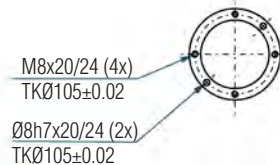
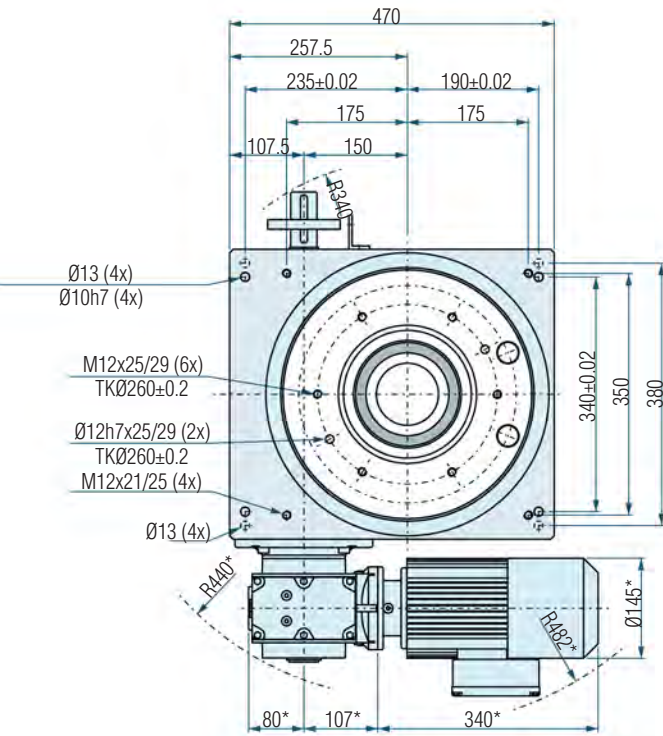
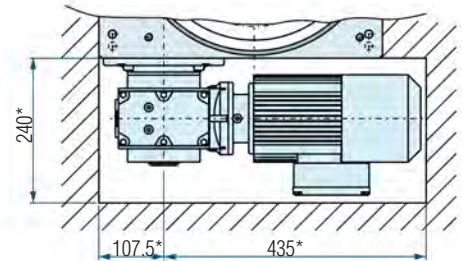
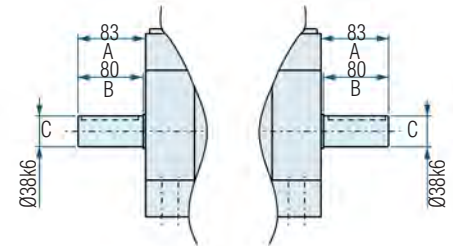
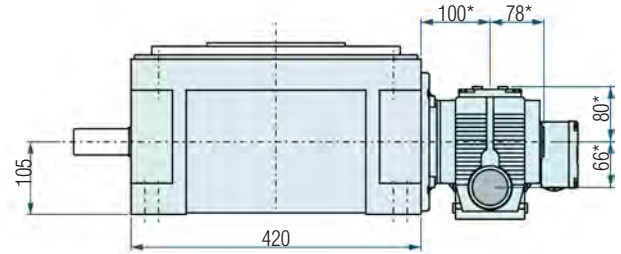
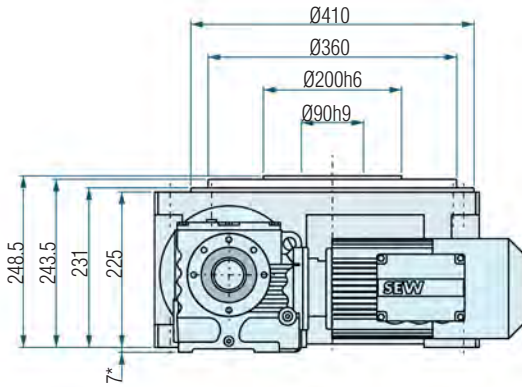

The dimensions for the gearmotor may change based on the gearmotor size and options required for the application.

TT315

Load Table

Scenarios

		1	2	3	4	5	6	7	8	9	10	11	12
2	t		0.38	0.59	0.78	1.13	1.56	1.77	2.06	2.38	2.97	3.27	4.13
	J		2.65	9.8	16.5	45	89	115	180	210	348	463	630
3	t		0.36	0.54	0.73	1	1.49	1.65	1.94	2.23	2.79	3.07	3.87
	J		5.3	20	33	92	175	238	365	427	698	940	1270
4	t	0.24	0.32	0.5	0.65	0.95	1.34	1.48	1.75	2	2.51	2.76	3.48
	J	2.95	7	23	42	102	225	295	420	552	920	1190	1650
5	t	0.24	0.32	0.5	0.65	0.95	1.34	1.48	1.75	2	2.51	2.76	3.48
	J	4.4	10.5	33	61	152	325	415	598	825	1370	1720	2450
6	t	0.24	0.32	0.5	0.65	0.95	1.34	1.48	1.75	2	2.51	2.76	3.48
	J	6.45	14.5	46	81.5	178	440	550	790	1095	1850	2320	3520
8	t	0.24	0.32	0.5	0.65	0.95	1.35	1.48	1.75	2	2.45	2.8	
	J	11.5	23.5	67	123	295	660	815	1220	1650	2610	3560	
10	t	0.24	0.32	0.5	0.65	0.95	1.35	1.48	1.78	2.05	2.45	2.84	
	J	16.5	33.2	90.5	167	395	890	1130	1570	2300	3460	4850	
12	t	0.24	0.32	0.5	0.65	0.95	1.35	1.51	1.78	2.17	2.48		
	J	22.1	42.5	110	216	510	1100	1420	2170	3025	4400		
16	t			0.25	0.33	0.47	0.67	0.74	0.88	1	1.21		
	J			47	81	206	375	455	645	720	1250		
20	t			0.25	0.33	0.47	0.67	0.74	0.89	1	1.24		
	J			64	110	230	460	570	760	1065	1520		
24	t			0.25	0.33	0.47	0.67	0.76	0.91	1.1	1.37		
	J			78	133	257	560	710	995	1340	2310		
30	t			0.25	0.33	0.47	0.72	0.78	0.9	1.1	1.37		
	J			95	163	345	790	940	1270	1910	2880		
36	t			0.25	0.37	0.5	0.71	0.93	1.18	1.48			
	J			113	253	451	940	1610	2380	4190			

Technical Specifications

Main Dimensions

Output Flange Ø [mm]	360
Overall Height [mm]	243.5
Center Opening Ø [mm]	90
Max. size of rotating plate Ø [mm]	2800
# of indexes	2,3,4,6,8,10,12,16,20,24,30,36
(other numbers on request)	
Index Table weight [kg]	193
Direction	CW, CCW, oscillating
Mounting Position	ANY

Load on output flange

Axial force [kN]	32
Radial force [kN]	17
Tilting moment [kNm]	5

Load on Central column

Axial force [kN]	28
Tilting moment [kNm]	4

Precision

Index precision ["]	±23
Axial Runout [mm]	±0.01
Radial Runout [mm]	±0.01

Standard Drive

Motor	SEW
Gear unit	SEW
Motor size	71-100
Voltage [V]	ANY
Power [kW]	0.37-2.2

* The precision is 5 - 8 angular seconds greater at 16 or more indexes due to multiple dwell positions on the drive cam.





MOTION
INDEX DRIVES

1204 East Maple Troy MI 48083
P: 248-743-9999 F: 248-743-0749
info@mid.us.com
www.motionindexdrives.com