



MOTION
INDEX DRIVES



TMF Series

Operating Manual



Table of Contents

1. Safety instructions	3
1.1. General	3
1.2. Validity of this documentation	3
1.3. Intended use	3
1.4. Installation	4
1.5. Transport and Storage	4
1.6. Identification Plate	4
1.7. Electrical Connection	4
1.8. Lifting and Lubrication & Oil and Grease Type Tables	5
2. Assembly and Mode of Operation	6
2.1. Programmable Index Drive	6
2.2. Fixed Index Drives	6
3. Operating Modes	7
3.1. Operation of Programmable Index Drive	7
3.1.1. Normal Operation	7
3.1.2. Jogging Operation	7
3.1.3. E-Stop Operation/Stopping out of Position	7
4. Maintenance	8
4.1. Maintenance	8
4.2. Inspection	8
4.3. Overhauling	8
5. Spare Parts and Wear Parts	9
5.1. Removing the Cam Follower	10
5.2. Installing the Cam Follower	10
5.3. Maintenance Plan	10
6. Technical Data	11
6.1. TMF2000	11
6.2. TMF3000	12
6.3. TMF4000	13
6.4. TMF5000	14
6.5. TMF8000	15
7. Transport	16
8. Spare Parts	17-19

1. Safety instructions

1.1. General

Before you install and start operating this index table, please read these safety and operation instructions carefully. You should also read all warning signs on the devices and bear in mind, that they may not be damaged, nor may they be removed. The installation, initial operation, and maintenance may only be carried out by qualified technical personnel. According to these safety instructions, persons are qualified who are familiar with the installation, assembly, start-up, operation, and maintenance of automated systems, and possess the appropriate qualifications. Safe operation of these devices depends on correct application. Keep the safety and operations instructions in an accessible place, and make it available to all personnel who have any kind of access to the devices. Disregard of this and other instructions contained within this book may cause the operator and the system to be exposed to danger, and this can lead to danger to the equipment, severe injury, or even death.



The index table may only be put into operation after the entire system in which it is integrated as well as the control and safety system conform to the machine guidelines and the appropriate domestic standards at the place of installation and operation.



Crushing Hazard. Keep adequately safe distance from moving parts!



Adhere to appropriate accident prevention regulations as well as generally acknowledged safety and occupational health regulations. Inadmissible modifications and the use of replacement parts and auxiliary equipment which are not recommended by the manufacturer can result in injury or material damage.



Before any work is done on the rotary table and its components, the drive is to be powered down and locked out against independent restarting!

Instructions: This operating manual was published in April 2013. The information contained within this documentation is the property of Motion Index Drives (MID), and may not be copied, reproduced, or forwarded to third parties without express written permission. With regard to the use of the information contained herein, no liability will be accepted. Furthermore, the information contained within this documentation can be changed without notice, since MID is constantly developing its high-quality products and gaining new insights. This operating manual has been drawn up with all necessary accuracy. MID accepts no responsibility for any errors or omissions, nor will any liability related to damages which result from the application of the information contained in this publication be accepted.

The CE certification is based on the following standards:

- EG machine guideline 98/37/EG
- EG low voltage guideline 93/68/EWG
- ER guideline for electromagnetic compatibility 89/336/EWG

1.2. Validity of this documentation

This operating manual is valid for all rotary index tables produced by Motion Index Drives, Inc.

1.3. Intended use

The sizing of the rotary table are to be carried out according to the tables and calculations displayed in this manual, and shall be carried out by technical sales personnel of MID.



The rotary index tables described herein are intended for use in normal industrial plants. They may not be installed into machines and equipment whose failure could put human lives directly at risk or cause great losses.



Standard units not to be used in an explosive environment. Any use of a rotary index table where safety may be in doubt is not permitted! Please contact Motion Index Drives before using the index table in such an environment as to ensure electrical components are suited for specific environments.

1.4. Installation

Rotary index tables must be installed in accordance with regulations outlined in the documentation. The installation position is user defined, and must be disclosed to MID when ordering the rotary index table.

Check before installation that the delivery is complete and correct.

Please verify that the rotary index table is correct by checking the identification plate, see Figure 2.

1.5. Transport and storage

Generally, rotary index tables should be stored and installed in a dry, clean environment. When transporting, only use means of transport and hoisting gear that has been approved for the weight of the rotary index table in question. In order to lift the rotary index table, please use three or more eye bolts. Tapped holes provided. (See table 1.1 for proper size)

1.6. Identification plate

The following information can be found on the ID plate:

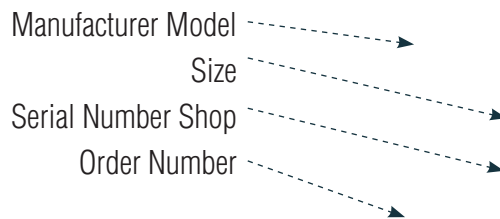

1.7. Electrical connection

(only applies if the drive is included)



Work on the electrical installation may only be carried out by trained specialists. Please adhere to all technical and country-specific regulations and standards during the installation. Our rotary index tables are driven by three-phase brake motors as standard. Connect the motor and brake only to the power supply as specified on the type plate. The motors must be protected from overload by means of motor overload switches or other suitable protective devices.

Figure 1

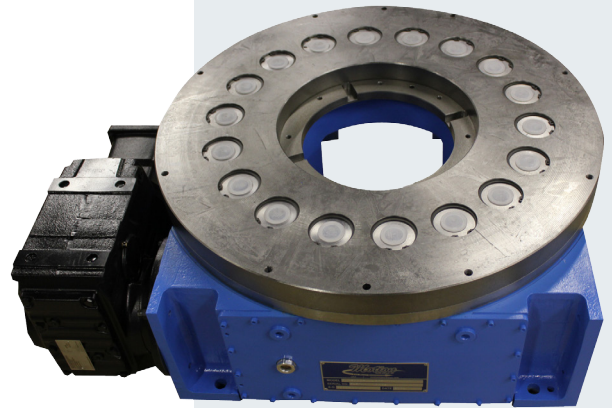

Figure 2



1.8. Lifting and Lubrication & Oil and Grease Type Tables Table 1.1

MODEL	WEIGHT LBS (APPROX)	WEIGHT KG (APPROX)	EYE BOLT SIZE	EYE BOLT QTY.	MAX OIL CAPACITY (L)
RT100	95	43	M8-15	4	0.3
RT160	150	70	M8-15	4	0.6
RT200	250	113	M8-15	4	0.75
RT250	320	145	M10-18	4	1.0
RT400	1300	590	M16-30	4	9.5
RT500	2500	1136	M20-30	4	18.5
RT630	4550	2068	M20-30	4	30
RT900	6500	2950	M24-40	4	50
TSR600	506	230	M16-30 M8-15	2 8	1
TSR1000	1188	540	M16-30 M10-18	2 12	9.5
TSR1600	1815	825	M24-25 M10-18	2 14	17
TT075	26.4	12	M6-12	4	0.45
TT125	52.8	24	M6-10	8	0.45
TT250	176	80	M10x20	4	1.1
TT315	411.4	187	M12x21	4	4.5
TMF2000	748	340	M12x20	12	4.5
TMF3000	1034	470	M12x18	14	7.5
TMF4000	1760	800	M12x24	30	9
TMF5000	2816	1280	M12x16	36	11
TMF8000	7656	3480	M36x55	3	40

Table 1.2 (Oil and Grease Types)

MANUFACTURER	GEAR OIL		LOW-VISCOSITY GEAR GREASE		GREASE FOR BALL AND ROLLER BEARINGS
	Mineral Oil Basis	Synthetic Oil Ba-sis	Mineral Oil Base	Synthetic Oil Ba-se	Lithium-saponied
BP	Energol GR-XP 460	Enersyn SG-XP 460	Energrase EP 0	Biogrease EP 0	Energrease LS2
DEA	Falcon CLP 460	Polydea PGLP 460	Glissando 6833 EP 00	N/A	Glissando FT2
ESSO	Spartan EP 460	Umlaufol S 460	ESSO Getriebefliefett	Fliebfett S 420	Beacon 2
Fuchs	Renolin CLP 460	Renolin PG 460	Renosod GFB	Renax GLS 00	Renolit FEP2
Kluber	Kluberoil GEM 1-460	Syntheso D 460 EP	Microlube GB 00	Klubersyn GE 46-1200	Microlube GL 262
Mobil	Mobilgear 634	Glygoyle 460 HE	Mobilex 44	Glygoyle Grease 00	Mobilux 2
Shell	Omaha OI 460	Tivela OI SD	Spez-Getriebe-fett H	Tivela Com-pound A	Alvania R2
Duration of Oil Change	In general the oil does not have to be changed. Please contact Motion Index Drives for detailed information regarding your application requirements.				
Grease Intervals	All models are completely maintenance free.				

2. Assembly and mode of operation

2.1. Programmable Index Drives

The rotary index table transforms a constant input drive motion into a constant output drive motion. The drive motion occurs by means of a flame or induction hardened and high-accuracy milled constant lead barrel cam. The use of mathematical laws of motion along with a properly programmed motor profile (see section 3.1) guarantee a soft, shock proof and jerk free movement that has been optimally designed for its intended purpose. The designed assembly allows for accurate and secure mounting to the output dial which is also backlash free. No additional adjustment of the output dial is necessary. Any additional modification to the index drive unit can result in damage to the indexing device.

The power to rotate the index drive is provided either by means of a three phase AC motor with encoder, coupled to a gear reducer, or a servo motor coupled to a gear reducer.

The gear reducer is connected to the input shaft which is firmly connected to the internal barrel cam with no further internal gearing. The barrel cam in turn rotates the top dial through the cam followers with a zero backlash internal design. The output dial is mounted to a wire bearing assembly (4 point contact bearing), which is preloaded to eliminate any runout. The index drive is completely sealed to eliminate intrusion from foreign particulate matter and fluids.

2.2. Fixed Index Drives

The rotary index table transforms a constant input drive motion into an intermittent output drive motion. The intermittent drive motion occurs by means of a flame or inductively hardened and high accuracy-milled barrel cam. The use of mathematical laws of motion guarantees a soft, shock-proof and jerk free movement that has been optimally designed for its intended purpose. The designed assembly allows for accurate and secure mounting to the output dial which is also backlash free. No additional adjustment of the output dial is necessary. Any additional modification to the index drive unit can result in damage to the indexing device. (see section 3.2)

The power is provided either by means of a three-phase brake motor via a gear reducer or by means of a chain-wheel or belt-wheel on the drive shaft of the rotary index table. This is firmly connected to the barrel cam, without any further internal gear sets, and it turns the cam followers and subsequently the output flange. The output flange is mounted within a wire bearing assembly, backlash free of play (within steel ring - not in casting). The index drive is completely sealed to eliminate intrusion from foreign particulate matter and fluids.

(Please see section 3 for proper utilization of fixed index drives)

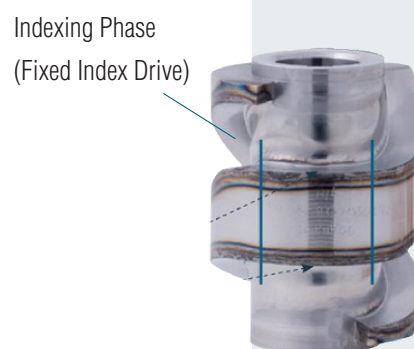
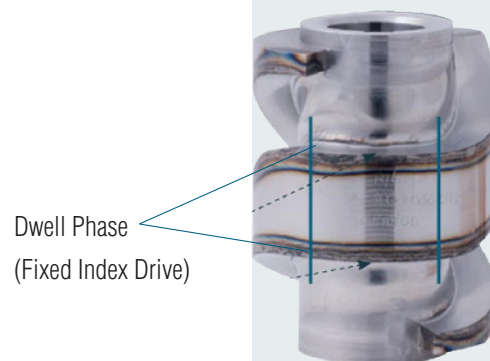
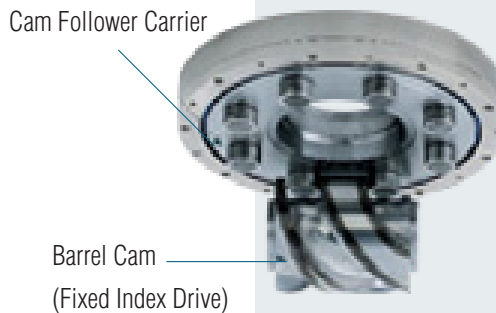

3. Operating Modes

3.1. Operation of Programmable Index Drives

All programmable index drives must be run on a VFD/Amplifier. The following MUST be followed to ensure proper operation and to prevent immediate and irreversible damage to the index drive.

3.1.1. Normal Operation

Normal Operation is defined as starting and stopping the index drive from two fixed points, or from position to position. Normal operation is the primary operation the index drive will function.

In Normal Operation, the index drive will have three unique speeds during one cycle. The unique periods are as follows:

ACCELERATION: This is the time the motor and index drive run from zero speed, 0 Hz, to a peak speed. The acceleration time should never be less than 0.5 seconds for a programmable index drive. Motion Index Drives will provide the acceleration time recommended for your VFD/Amplifier parameters. The peak speed to accelerate to will also be provided for your application, traditionally set to 60 HZ MAX!

CONSTANT VELOCITY: This is the time the motor runs at a constant speed, once acceleration is complete. This time is determined on an application by application basis. In some cases, there is 0 seconds constant velocity, please check with Motion Index Drives, Inc. for your application. Total Index Time minus acceleration and deceleration time is equal to the constant velocity time.

DECELERATION: This is the time the motor and index drive run from peak speed (60HZ normal) to 0 Hz, or zero speed. This time is determined on an application by application basis. The deceleration time should never be less than 0.6 seconds.

NORMAL OPERATION PARAMETERS:

Acceleration: 0.5 seconds or more - Application Dependant

Deceleration: 0.6 seconds or more - Application Dependant

Frequency: Based on customer application. Never exceed 60Hz max motor frequency unless otherwise instructed by Motion Index Drives, Inc.

EXCEEDING MOTION INDEX DRIVES RECOMMENDED FREQUENCY AND/OR JUMPING FREQUENCIES DURING NORMAL OPERATION WILL IMMEDIATELY VOID WARRANTY.

3.1.2. Jogging Operation

Jogging is defined as rotating the index drive in a slow, manual mode. This is typically done in the initial setup.

For jogging, it is recommended to run the index drive at a much slower frequency (i.e. 20HZ), and accel/decel rates are suggested at 0.5 seconds.

3.1.3. E-Stop Operation/Stopping out of Position

E-stop conditions are defined as the immediate stop of the index drive due to one of many factors, including operator light screen or safety mat being activated, robot errors, or e-stop buttons being activated and involve the requirement of the index drive to stop out of a programmed position. Operating the index drive properly with a VFD/Amplifier during e-stops, or stopping out of position is critical to ensuring the indexers operation. During the e-stop, if dynamic braking is being utilized in the VFD/Amplifier, ensure that the dynamic braking time is not any less than 0.6 seconds. Longer braking time is acceptable. During e-stop, it is critical to ensure that the dynamic brake is not driving through the brake of the motor if the motor is equipped with one. The brake circuit should be applied after the dynamic braking time. To restart from an e-stop or out of position stop, it is suggested to accelerate the motor to the peak motor frequency if applicable using the same acceleration time provided in normal operation. The same deceleration time should also be followed when approaching the next known position in the normal operation mode.

E-stop/Stopping Out of Position Parameters:

Acceleration: 0.5 seconds or more – Application Dependant

Deceleration: 0.6 seconds or more - Application Dependant

Frequency: Based on customer application. Never exceed 60HZ max motor frequency unless otherwise instructed by Motion Index Drives, Inc.

Dynamic Brake Time/Decel Time during e-stop: >0.6 seconds



Warning: It is imperative that the controls individuals understand this operation prior to commissioning an index drive. For any questions, please contact Motion Index Drives, Inc. prior to commissioning index drive to prevent irreversible damage to the index drive from improper operation. Improper operation of the index drive with variable frequency drive will immediately void warranty!



Warning: Motors supplied w/brake: Brake is only used for holding position and should NEVER be used for stopping indexer under normal conditions or during an emergency stop!

4. Maintenance

Maintenance includes inspections, servicing and overhauling. Maintenance work may only be undertaken by an experienced specialists.



Before working on the rotary index table and related tooling, switch the drive off electrically and make sure it cannot restart by itself. Proper lockout procedures must be followed.

4.1. Maintenance

The index tables and the gear reducer on the drive do not need to be regularly filled with oil for the duration of their life in normal environments and applications. If for any reason oil is drained, the filling amounts can be found in the operating manual for the drive. The type of oil to be used is Mobilgear XP460.



Do not mix mineral lubricants with synthetic lubricants.

4.2. Inspection

The intervals specified must be adjusted to suit the conditons.



Switch the drive off electrically and make sure it cannot restart by itself.

Every six months visually inspect for damage. Remove any deposit of dust (especially on the ventilation grille of the motor) and examine the electrical cables for damage.

Every six months check the rotary index table for play in the dwell position

4.3. Overhauling

If the rotary index table is damaged, please contact Motion Index Drives, Inc. Only repairs performed by an MID certified technician ensures proper functionability and optimal performance. Any unauthorized opening of the casing will void the warranty.

The rotary index table must be checked for play. If there is any play in one or more stations, the cam rollers have to be replaced.



All cam followers may have to be replaced. Check whether the mounting holes for the cam followers in the output dial flange are still round and true to size. If holes are out of round the output dial flange will have to be replaced.

5. Spare Parts and Wear

Motion index Drives, Inc. rotary index tables are practically maintenance free when commissioned correctly, and loading and operating environment are clearly defined by the customer to MID. The cam followers do not cause any wear and tear on the hardened cam tracks; all roller bearings are oversized and run through an oil bath. For reasons of safety, only replacement parts which are of the same quality as the original parts may be used. When ordering, please give the following data:

- Model and shop order number, see ID plate
- Name
- Quantity

Wear parts are marked (x). Please order replacement parts set. The quantity or amount of the cam followers and lubricants depend on the model and design of the rotary index table.

Number	Quantity	Name
01	1	Housing
02	1	Input Shaft
05 (x)	2	Shaft Seal
06 (x)	2	Locknut Input Shaft
07 (x)	2	Tapered Roller Bearing
08 (x)	1	Locknut Cam
09	1	Barrel Cam
10	1	Central Column
12 (x)	1	O-Ring
13	1	Output Flange / Drive Flange
14 (x)	1	Inner Top Dial Seal
15 (x)	n*	Cam Follower
16 (x)	1	Outer Top Dial Seal
18 (x)	1	Four Point Contact Bearing
19 (x)	1	Adjustment Ring for Four Point Contact Bearing
20 (x)	1	O-Ring
21 (x)	1	O-Ring
22 (x)	1	Center Ring for Four Point Contact Bearing
23 (x)	1	Shaft Seal
26	1	Housing Cover
	n*	Depending on Number of Indexes

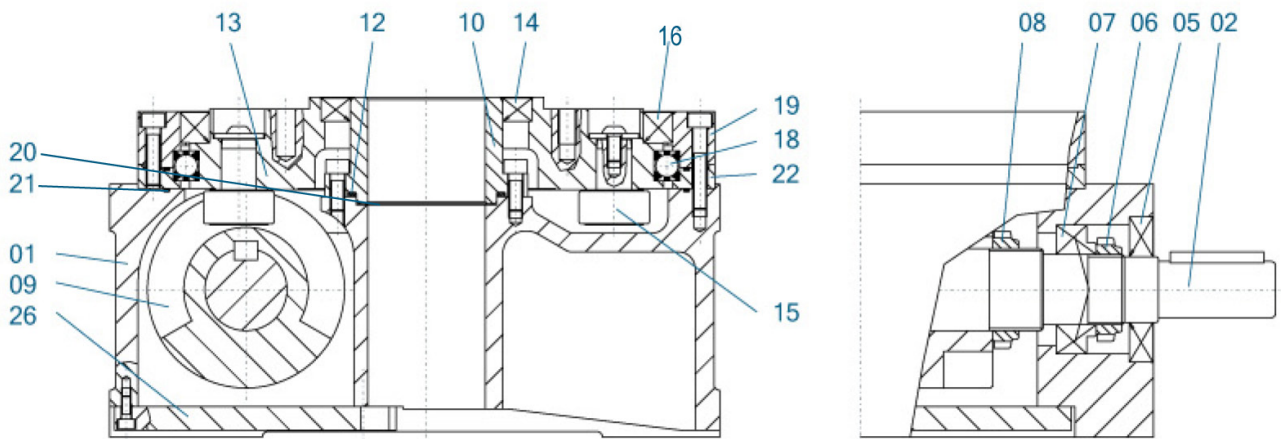

5.1 Removing the Cam Follower

Start by removing the cap plug (item 70). Then use the cir-clip pliers to remove the retaining ring (item 60). After the hexagonal bolt (item 50, including 40 and 30) has been re-moved, together with the two washers, an internal thread becomes accessible in the cam follower insert. Screw the internal extractor into the internal thread of the cam follow-er insert. After applying a lubricant, the cam follower insert is then carefully pulled from the top dial using the internal ex-tractor.



Steps must be taken to ensure that no foreign bodies can get inside the barrel cam rotary indexing table. It is recommended that the holes from which the cam follower insert have been withdrawn should be covered.

It is easier to remove the cam follower if the cylindrical sur-face is heated. As soon as this has been done, a suitable bolt can be used to press the cam follower out.

5.2 Installing the Cam Follower

The cam follower insert (item 20) is heated in order to facili-tate insertion of the cam follower (item 10). After the cam follower has been pressed into the cam follower insert, we recommend that you wait for a short time for the insert to cool before continuing assembly. In the following order, fit the washer (item 30), the Schnorr locking washer (item 40) and the hexagonal bolt (item 50). Tighten the bolt to the maximum torque (see torque table). To facilitate installation of the cam follower insert (item 20) with the cam follower, you should cool the insert. Once cooling is complete, press the insert into the correct hole in the top dial without can-ting. The cam follower insert is held in position by the circlip (item 60). The cap plug must be pressed into the correspon-ding hole so that it is approximately 0.5 mm below flush. The cap plugs must not protrude from the top dial. Check the positions of the cap plugs again before the barrel cam rotary indexing table is taken into operation.

5.3 Maintenance Plan

Interval	Maintenance Activity	Staff
Daily	General visual and acoustic inspection.	Operator
Monthly	Check that no oil is escaping from the cylinder cam rotary indexing table.	Operator
Six-Monthly	Visual inspection for damage. Remove any dust deposits (especially on venti-lation grills of the drive unit). Inspect electric cables for damage.	Qualified Staff
Six-Monthly	TMF8000 Visual inspection of the belt drive. Replace belt drive if necessary.	Qualified Staff

TORQUE TABLE	
Steel bolts (Grade 8.8)	Torque (Nm)
M4	3.3
M5	6.5
M6	11.3
M8	27.3
M10	54
M12	93
M14	148
M16	230

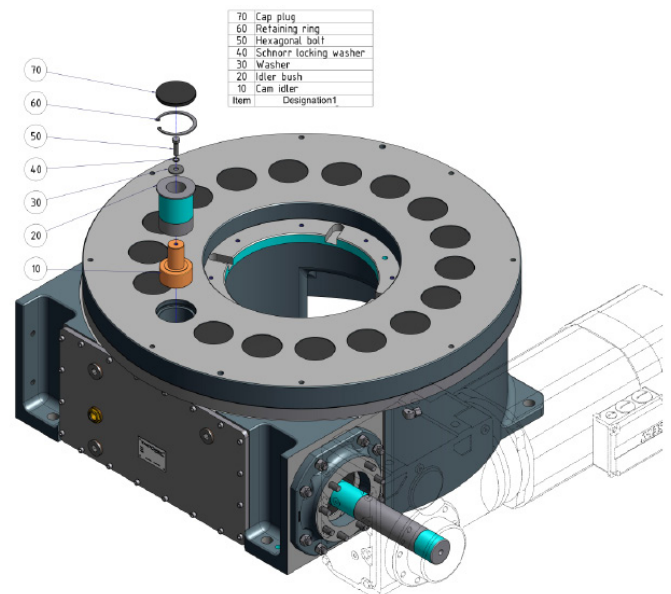

6. Technical Data
6.1 TMF2000

Primary Dimensions	TMF2000
Top Dial Diameter [mm]	560
Height (mounting surface of top dial) [mm], w/baseplate, no leveling	285
Internal Diameter [mm]	190
Approx. Weight of Rotary Table w/gear reducer, baseplate, & motor lbs	771.61
Internal Transmission Ratio [i]	14
Indexing Precision in Angluar Seconds [„]	8

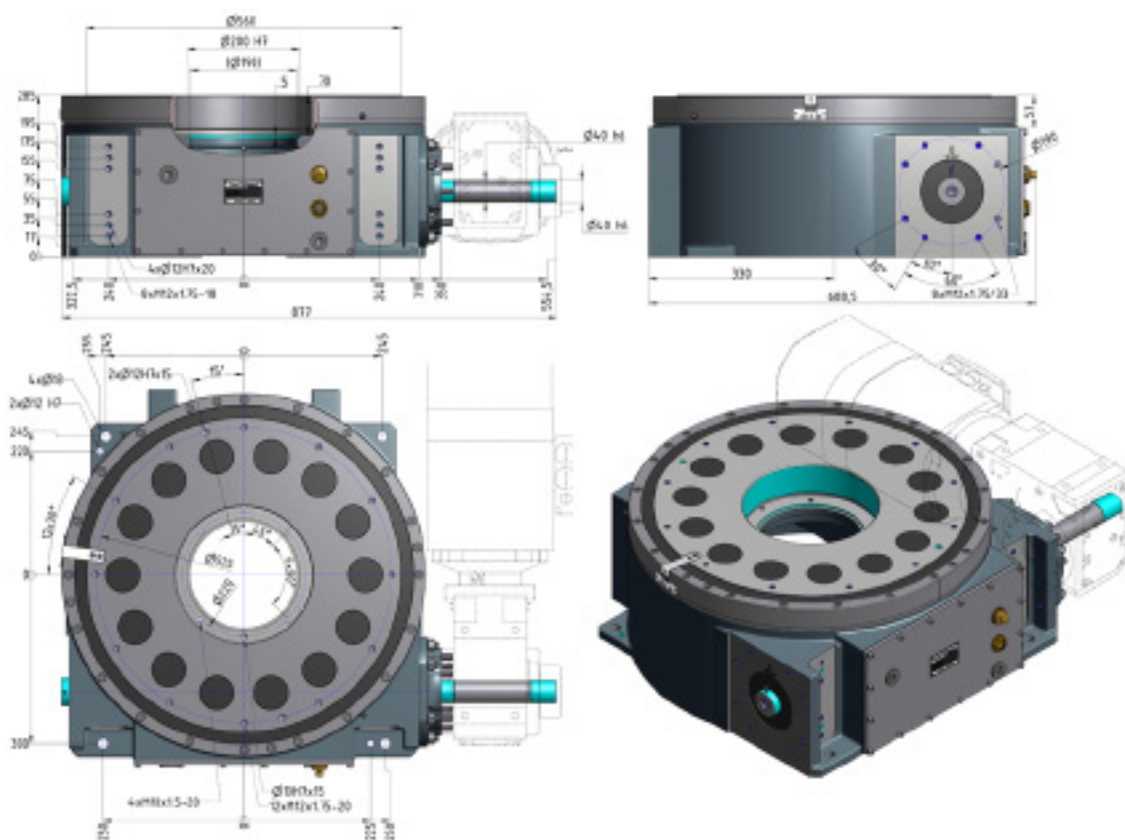

6.2 TMF3000

Primary Dimensions	TMF3000
Top Dial Diameter [mm]	800
Height (mounting surface of top dial) [mm], w/baseplate, no leveling	330
Internal Diameter [mm]	280
Approx. Weight of Rotary Table w/gear reducer, baseplate, & motor lbs	1058.22
Internal Transmission Ratio [i]	18
Indexing Precision in Angular Seconds [„]	8

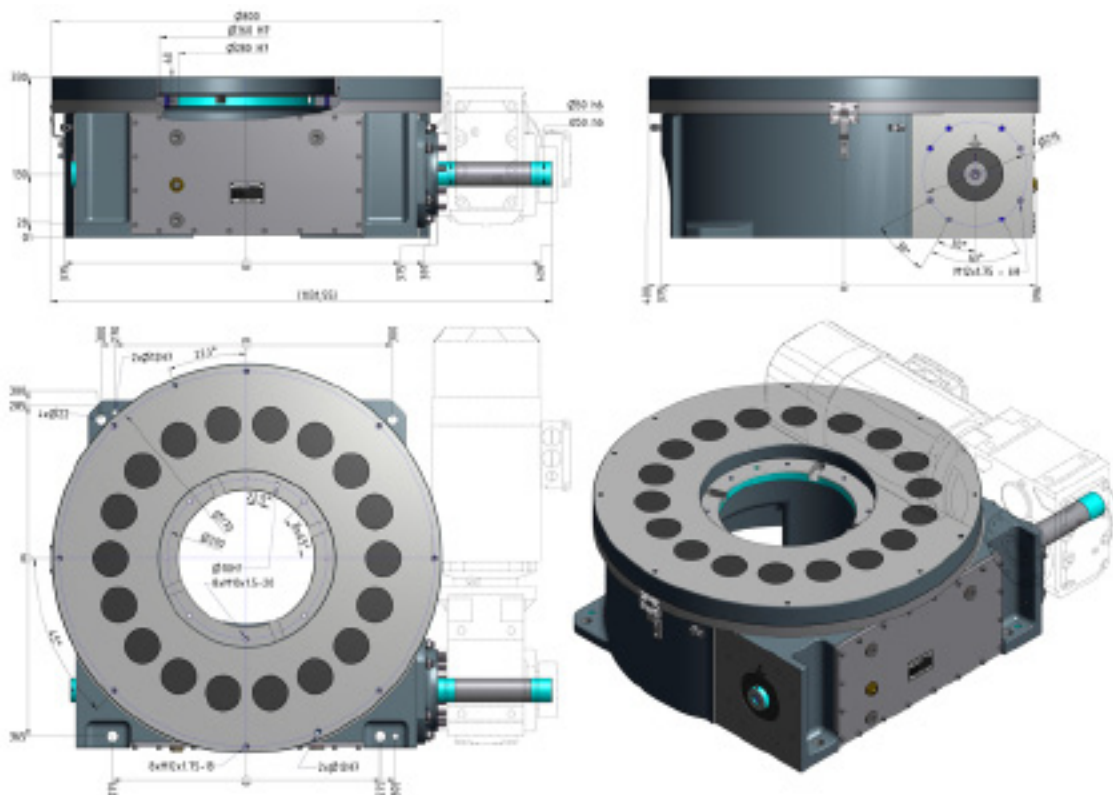

6.3 TMF4000

Primary Dimensions	TMF4000
Top Dial Diameter [mm]	1,050
Height (mounting surface of top dial) [mm], w/baseplate, no leveling	365
Internal Diameter [mm]	450
Approx. Weight of Rotary Table w/gear reducer, baseplate, & motor lbs	2,006.21
Internal Transmission Ratio [i]	
Indexing Precision in Angluar Seconds [,,]	

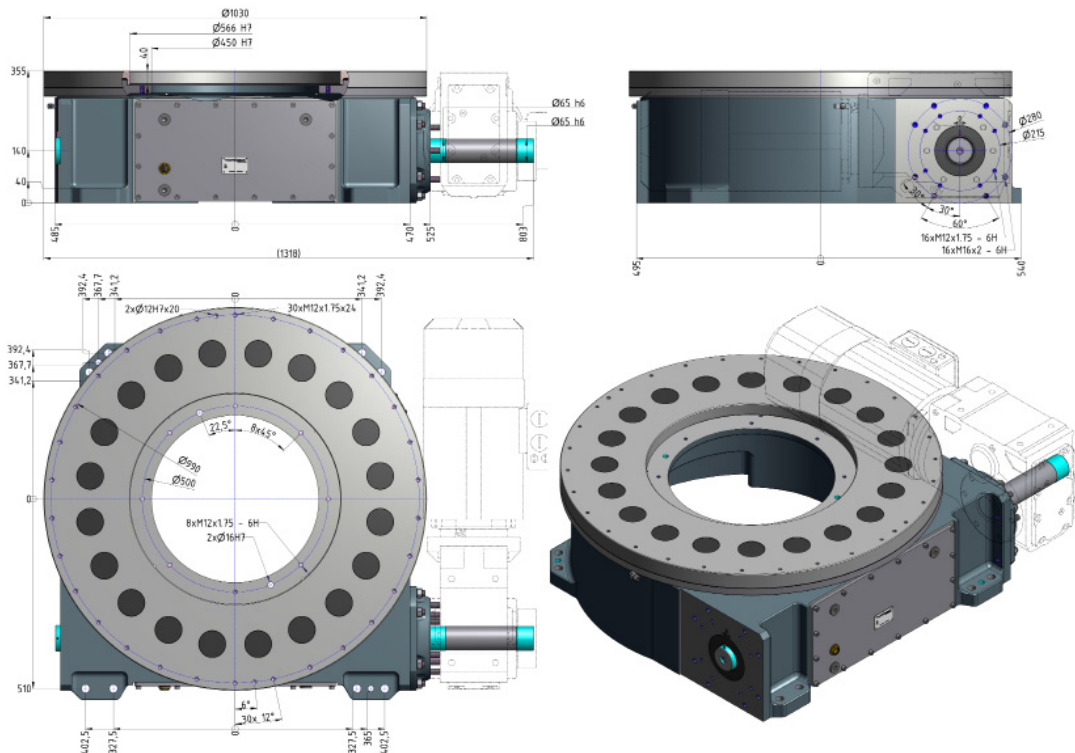

6.4 TMF5000

Primary Dimensions	TMF5000
Top Dial Diameter [mm]	1,360
Height (mounting surface of top dial) [mm], w/baseplate, no leveling	405
Internal Diameter [mm]	750
Approx. Weight of Rotary Table w/gear reducer, baseplate, & motor lbs	2,810.89
Internal Transmission Ratio [i]	24
Indexing Precision in Angluar Seconds [,,]	8

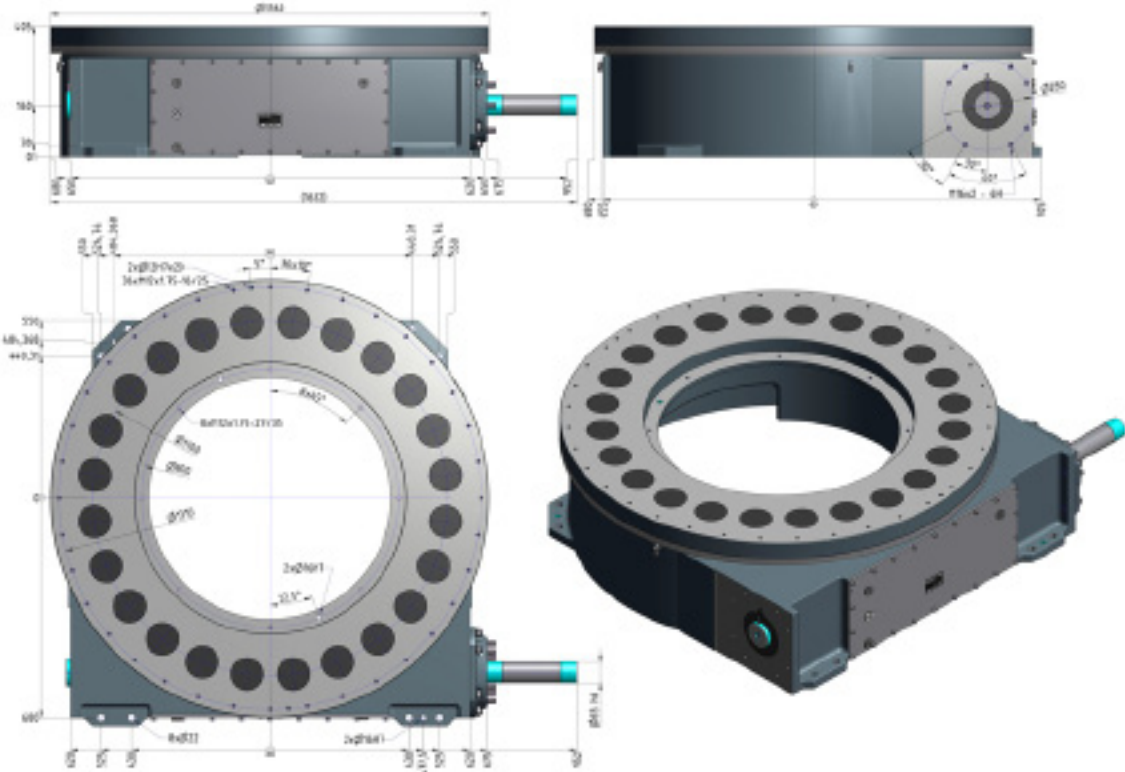

6.5 TMF8000

Primary Dimensions	TMF8000
Top Dial Diameter [mm]	2,570
Height (mounting surface of top dial) [mm], w/baseplate, no leveling	440
Internal Diameter [mm]	1520
Approx. Weight of Rotary Table w/gear reducer, baseplate, & motor lbs	8,377.56
Internal Transmission Ratio [i]	40
Indexing Precision in Angular Seconds [,,]	8

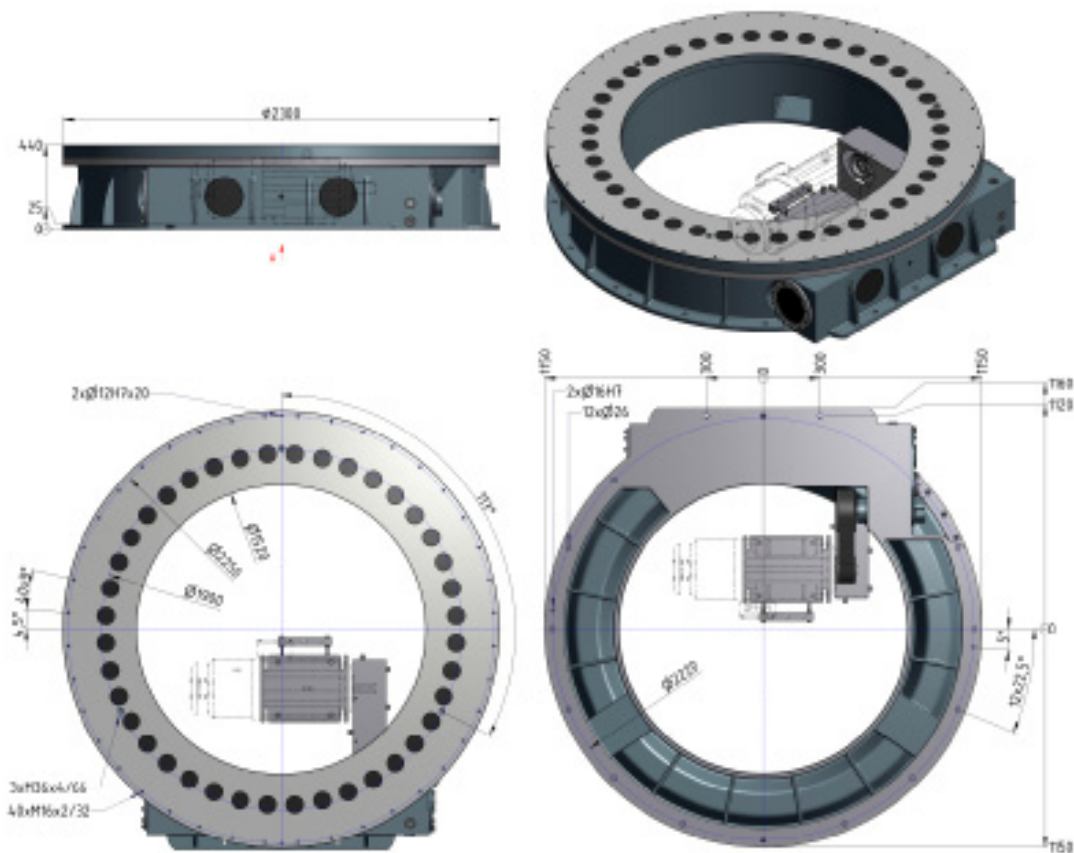

7. Transport

The slinging equipment (see figure) must be attached in the threaded holes (see table and dimensions sheet) in the positions shown in the figure and checked to ensure that it is working correctly (see the instructions for the slinging equipment).

Thread table for screw attachment points:

Suitable threaded holes are provided on cylinder cam rotary indexing tables to accommodate slinging equipment. Please refer to the dimensions sheet in the technical data for the thread sizes.

Type	# of slinging points	Recommended slinging equipment	Thread
TMF2000	3	VLGB 1t	M12
TMF3000	3	VLGB 1t	M12
TMF4000	4	VLGB 1t	M12
TMF5000	4	VLGB 1t	M12
TMF8000	3	VLGB 8t	M36

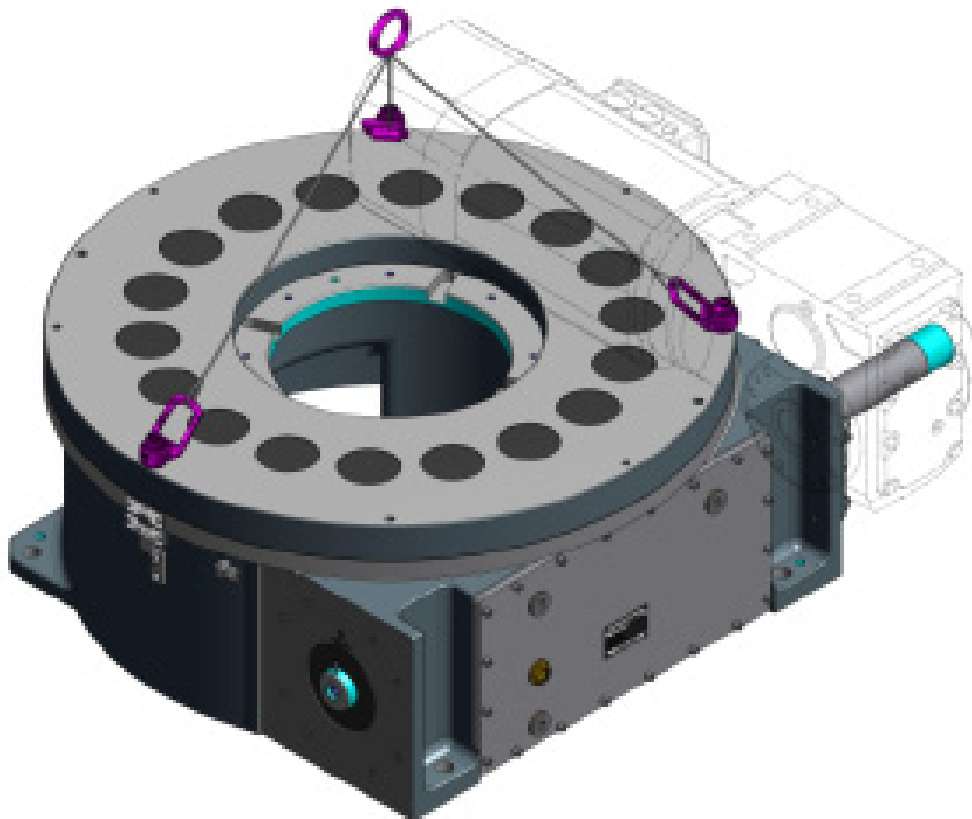

8. Spare Parts

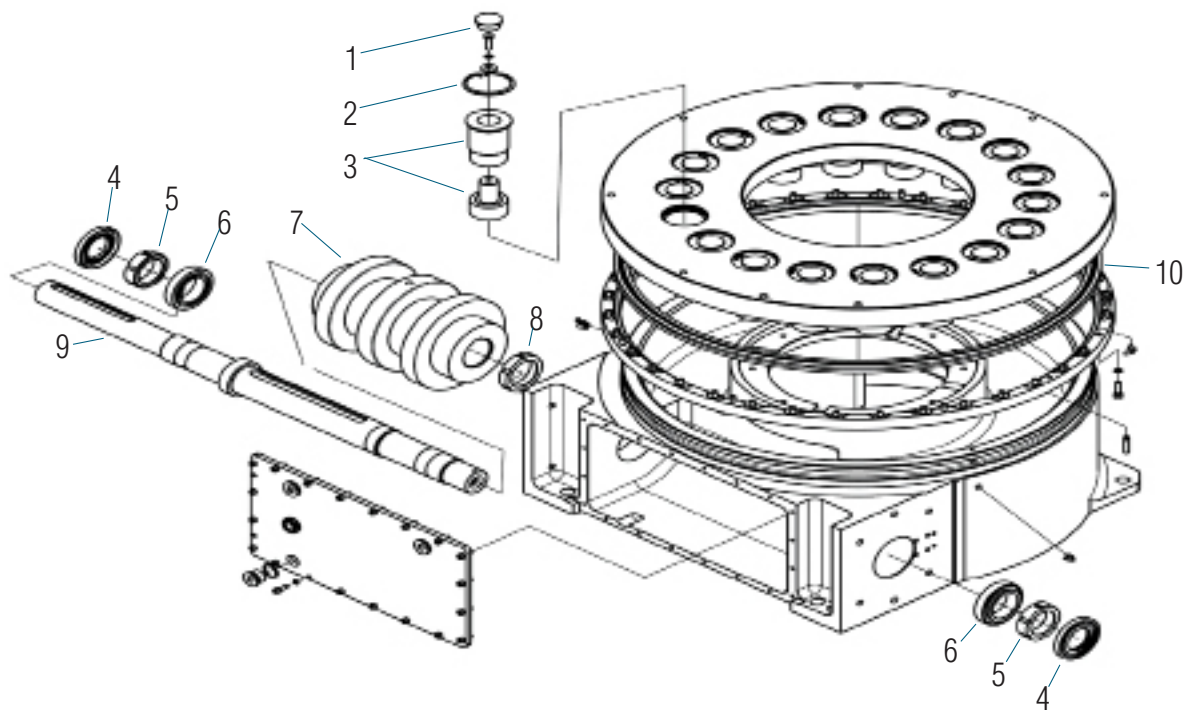

TMF2000-5000 USE IMAGE ABOVE, TMF8000 USE IMAGE BELOW

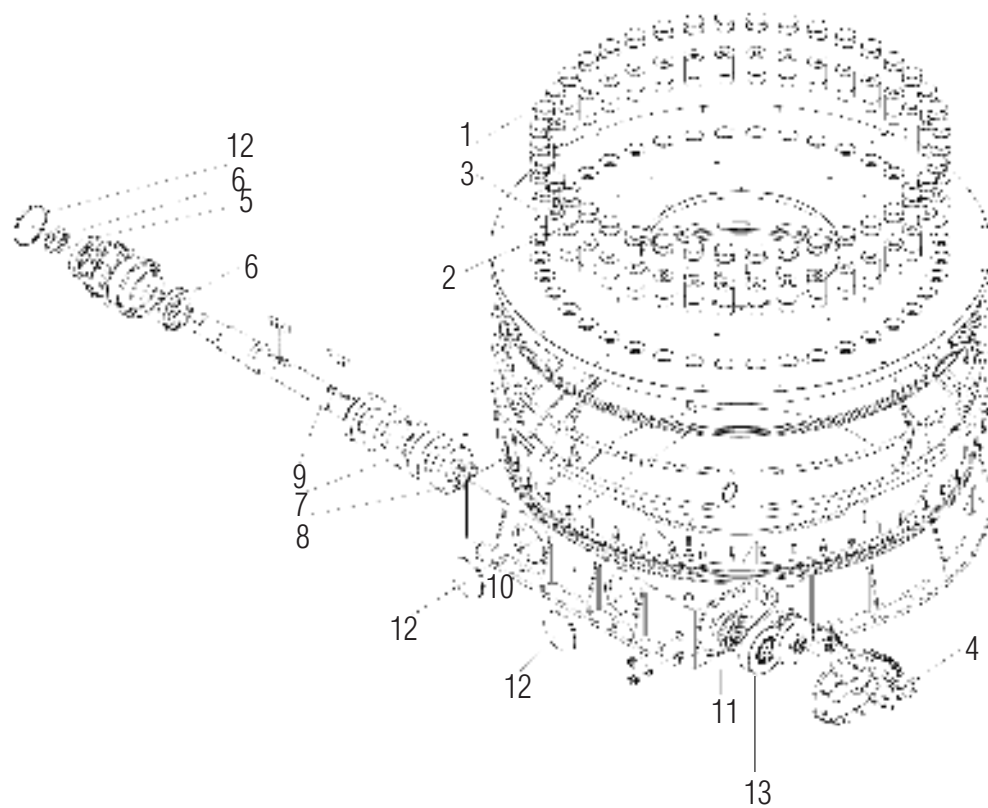

TMF2000			
Item #	Part #	Description:	Qty:
6	03-10111	TMF2000 shaft taper roller bearing	2
4	24-10094	50MM shaft Dia; 90MM Housing Bore; 10MM Nominal Width; Nitrile Lip; Solid Seal; 10MM Actual Width; Spring Loaded; 2 Sealing Lips; Carbon Steel Garter	2
1	24-10138	Cam folloer cap seal VK60x8	14
10	26-10031	4 fount point slewing ring	1
5	09-10288	Mechanical locl nut for shaft	2
8	09-10289	Mechanical lock nut for cam	1
7	15-10013	Indexing barrel cam	1
9	25-10060	input shaft	1
N/A	24-10137	o ring cam followers	14
N/A	24-10139	top dial seal 560x600x18	1
3	50-06-10065	Cam follower Assembly	14

TMF3000			
3	50-06-10064	Cam follower assembly 60	18
6	03-10035	Tapper roller bearing on input shaft: Tapered Roller Bearing: I.D.: 55mm O.D.: 90mm Minimum Dynamic Load Rating 80.9kn Minimum Static Load Rating: 116kn	2
4	24-10094	50mm Shaft Dia; 110mm Housing Bore; 10mm Nominal Width; Nitrile Lip; Solid Seal; 10mm Actual-Width; Spring Loaded; 2 Sealing Lips; Carbon Steel Garter	2
1	24-10023	72x9 cap seal top dial	18
10	26-10025	4 fount point slewing ring	1
5	09-10176	Mechanical lock nut for shaft	2
8	09-10177	Mechanical lock nut for cam	1
7	15-10007	Indexing barrel cam	1
9	25-10047	input shaft	1
N/A	24-10095	o ring cam followers	18

TMF4000			
3	50-06-10069	Cam follower assembly	20
2	06-10099	Cam follower locking ring	20
10	26-10033	Top dial slewing ring	1
6	03-10121	Shaft bearings	2
5	09-10311	Shaft locknut	2
8	09-10312	Cam locknut	1
4	24-10148	Shaft seal	2
1	24-10148	Cam follower cap seal	20
7	15-10018	Barrel Cam	1

TMF5000			
3	50-06-10066	Cam follower assembly	24
2	06-10089	Cam follower locking ring	24
10	26-10024	Top dial bearing assembly	1
6	03-10046	Tapered roller bearing I.D. 40mm O.D. 68mm. 1 single cone 1 single cup. Minimum dynamic load Rating 168kn Minimum static load rating 270kn	2
5	09-10183	Mechanical lock nut w/high precision thread	1
8	09-10184	Mechanical lock nut w/high precision thread	1
4	24-1011	85x150x12TC double lip seal	2
1	24-10110	100x10VK seal	24
7	15-10009	Barrel Cam	1
9	25-10061	Input shaft	1
TMF8000			
9	25-10065	Input shaft	1
7	15-10017	Barrel cam	1
3	50-06-10068	Cam follower assembly	40
11	03-10120	Main shaft bearing non gear side NTN 30319	1
10	26-10033	Top dial bearing/slewing ring	1
	03-10119	Main shaft bearing gear side NSK N219M	2
4	24-10057	Gear set input shaft oil seal HAW 50x90x10ADL	1
1	24-10109	Cam follower seal caps HAW 90x10VK	40
6	24-10146	Main shaft seal non gear side HAW 200x13VK	2
5	09-10184	Shaft locknut 95x2	2
8	09-10310	Cam locknut 105x2	1